

TYPE	OUTPUT		POLE	TIME RATING	VOLTAGE V	Hz	SYN.SPEED R.P.M
	HP.	kW.					
AEHH8B	100	74.6	8	CONT.	460	60	900

TOTALLY ENCLOSED FAN-COOLED TYPE. SQUIRREL-CAGE ROTOR

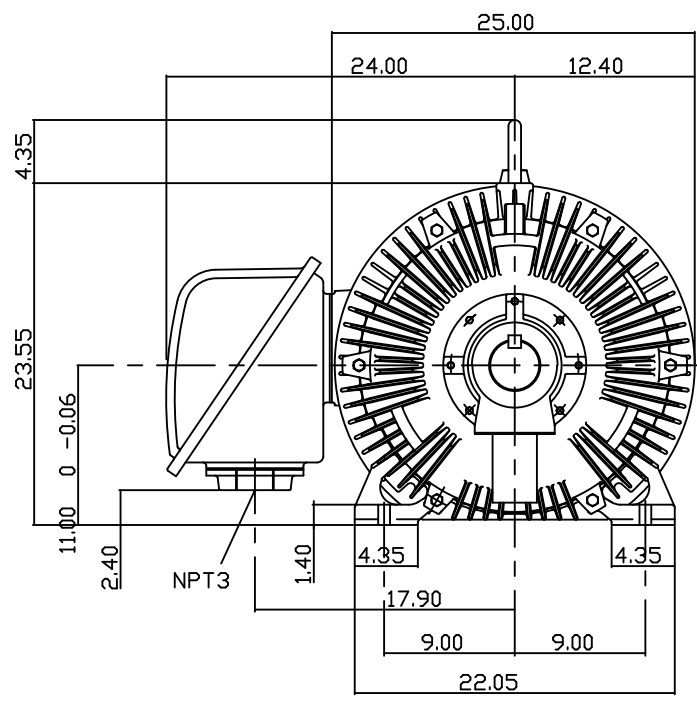
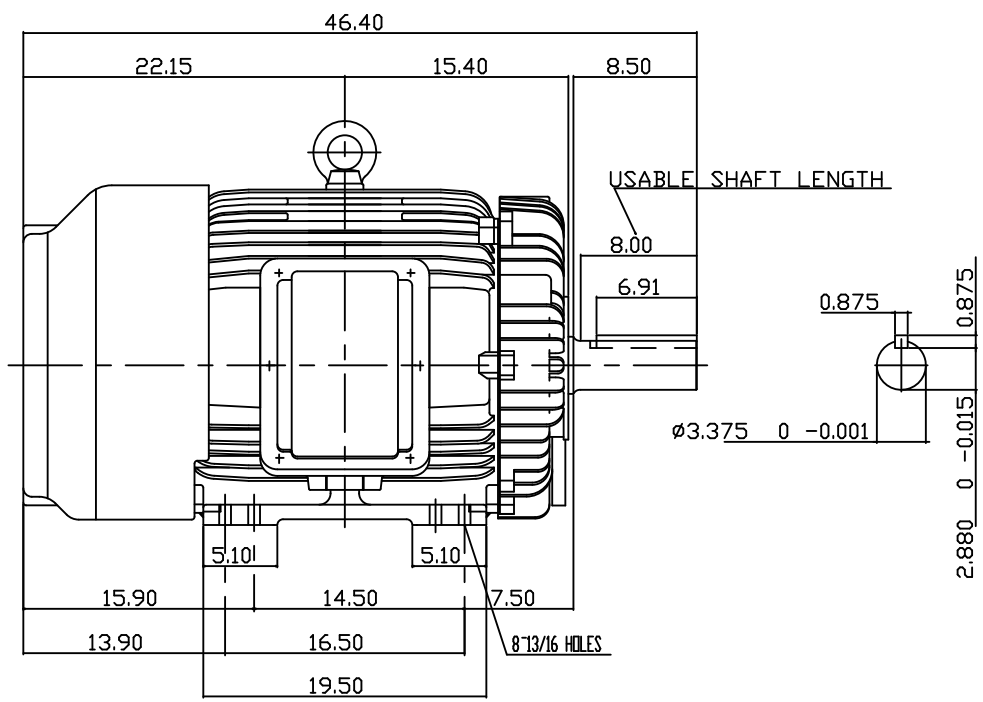

- NOTE:
1. DIMENSIONS IN INCH
 2. FRAME NO. 445T
 3. F CLASS INSULATION, S.F.115
 4. FOR DIRECT FLEXIBLE COUPLING
 5. ENCLOSURE: IP54
 6. BEARING SIZE DRIVE END: 6318C3
NON-DRIVE END: 6316C3
 7. APPROX. WEIGHT: 2088 LBS

TW-56C

DWN.	T.H.Pan	FEB 18 2005
CHKD.	H.HUANG	FEB 18 2005
APPD.	C.WANG	FEB 18 2005

DATE 12-20-11	OUTLINE DIMENSIONS
CATALOG #EP1008	3-PHASE INDUCTION MOTOR
TEC Westinghouse	
DWG. NO. 3A040Y698	REV: 00